

Streaming Potential Transmitter (SPT1000)

The transmitter measures electrical charge intensity in the water sample, which is dosed with coagulant and sends the measured signal to the streaming potential detector. Since the water sample continuously passes through the transmitter probe, process changes can be detected instantly. Additionally, the probe is designed to buffer the water sample in its measuring area, so that a stable signal results, even when variations occur in the sample flow rate. The sensing elements in the probe prevent fouling by utilizing a high torque motor to ensure a fast and powerful relative movement between the two parts of the probe, while the water sample passage in the probe is also designed to be clog free. Thus the probe is able to perform sensitive measurements over long periods of time with virtually no maintenance.

Streaming Potential Detector (SPD1000)

The detector receives the measured streaming potential signal from the streaming potential transmitter and converts it into industrial standard output signals, 4-20 mA and 0-5VDC, for treatment control applications. The detector also provides the following functions.

1. Absolute and Relative Signals
A switch is provided to select either an absolute or a relative streaming potential signal. The absolute signal, which can not be adjusted, is the absolute measurement of the process water's electrical charge. The relative signal serves as an adjustable baseline.
2. Theoretical vs. Practical Optimum Point
The zero (0.00) point of the absolute signal indicates the electrical charge neutral point, which is the theoretical optimum coagulant dosage point. The zero (0.00) point of the relative signal can be adjusted to the customer's desired dosage point, which is the practical optimum point. In order to find this practical optimum dosage point, Sentrol recommends using the theoretical optimum point as a base, and then tuning the relative signal to meet this practical optimum dosage point.
3. High/Low Sensitivity Selection
A jumper is provided to select high sensitivity or low sensitivity measurement for different industry applications.
4. High/Normal Signal Gain
The detector's relative signal can be adjusted with high or normal gain for display and control purposes.
5. High/Low Alarm Indicators and Contacts
Streaming potential signal high and low alarm limits can be set through the detector front panel, limit range is from -5 to +5. As soon as the measured signal is beyond the set limits, the corresponding indicator and contact will activate until the signal comes back within the limits.
6. LED Digital Voltmeter Display
A digital panel meter can be selected to display absolute signal, relative signal, or high or low alarm limit.
7. Normal Operation Indicator
A flashing green LED indicates normal operation of the transmitter.

Specifications

Streaming Potential Transmitter (SPT1000)

| | |
|-----------------------------------|--|
| Power..... | Standard: 115VAC, 60HZ Optional: 230VAC, 50HZ |
| Sample Inlet...Low Concentration: | 5/8" Tubing ID Adapter |
| High Concentration: | 90 Degree, 1.25" Elbow |
| Sample Flow Rate..... | 1 ~ 5 Gal/Min. |
| Wetted Parts..... | Delrin, PVC, Stainless Steel, Nylon |
| Enclosure..... | Nema 4X, Polycarbonate Cabinet |
| Operating Temperature..... | 32 Degree F ~ 120 Degree F |

Streaming Potential Detector (SPD1000)

| | |
|--------------------------------------|--|
| Power..... | Standard: 115VAC, 60HZ Optional: 230VAC, 50HZ |
| Absolute Signal Display Range..... | -5 ~ +5 |
| Relative Signal Display Range..... | -5 ~ +5 |
| Relative Signal Zero Adjustment..... | -5 ~ +5 |
| Output Signals..... | 4 ~ 20 mA, 1 ~ 5 VDC |
| Sensitivity Selection..... | P15 on Circuit Board, Pin1,2: High Sensitivity; Pin2,3: Low Sensitivity. Consult Manufacturing Company |
| Meter Readout..... | Digital LED, -5 ~ +5 Range |
| Alarm Contacts..... | 8A at 250VAC or 5A at 30VDC DSP Relays |
| Alarm Adjustment Range..... | -5 ~ +5 |
| Gain Selection..... | Normal Gain: X1, High Gain: X10 |
| Enclosure..... | Nema 4X, Polycarbonate Cabinet |

Dimensions

Streaming Potential Detector (SPD1000)

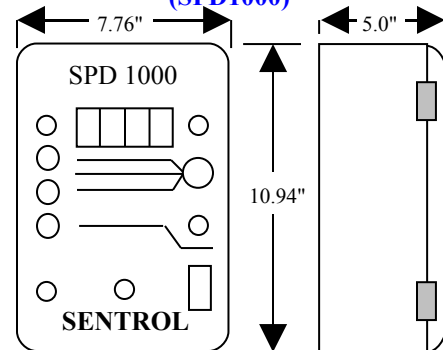

Streaming Potential Transmitter (SPT1000)

